

8RFB 1303

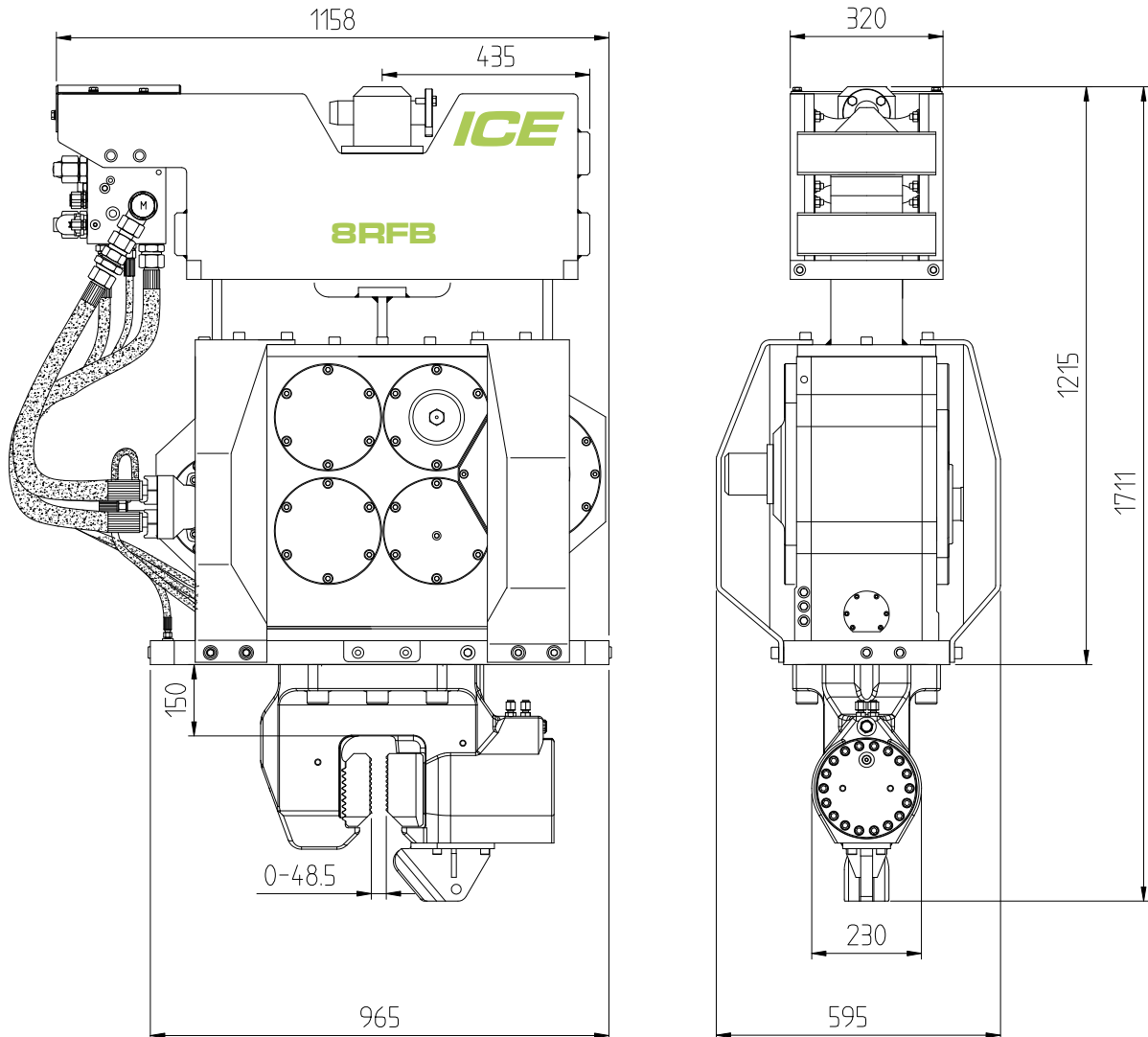

#### Specifications

#### 8RFB

Eccentric moment	0 – 7.5	kgm			<b>Clamps:</b>		
Max. centrifugal force	0 – 435	kN			Sheet pile clamp	60TU	
Max. frequency	2300	rpm			Weight	250	kg
Max. amplitude excl. 60TU	15	mm			Double clamps		
Max. amplitude incl. 60TU	13,8	mm			Weight		kg
Max. static line-pull	120	kN					
Max. operating pressure	350	bar			<b>Powerpack:</b>		
Max. oil flow	185	l/min			Model		
Dyn. weight excl. 60TU	985	kg					
Dyn. weight incl. 60TU	1235	kg					
Total weight incl. 60TU	1515	kg			<b>Forced lubrication:</b>		
Transport weight	1615	kg			Max. oil flow	22	l/min

Technische Daten:		8RFB		
Statisches Moment	0 – 7.5	kgm	<b>Klemmzange :</b>	
Max. Fliehkraft	0 – 435	kN	Universalzange	60TU
Max. Drehzahl	2300	UPM	Gewicht	250 kg
Max. Amplitude ohne 60TU	15	mm	Rohrklemmzange	
Max. Amplitude mit 60TU	13,8	mm	Gewicht	kg
Max. Statische Zugkraft	120	kN		
Max. Betriebsdruck	350	Bar	<b>Aggregat :</b>	
Max. Fördermenge	185	l/min	Modell	
Dyn. Gewicht ohne 60TU	985	kg		
Dyn. Gewicht mit 60TU	1235	kg		
Gesamtgewicht mit 60TU	1515	kg	<b>Zwangsschmierung :</b>	
Transportgewicht	1615	kg	Max. Ölmenge	22 l/min

Spécifications:		8RFB		
Moment excentrique	0 – 7.5	kgm	<b>Pinces:</b>	
Max. Force centrifuge	0 – 435	kN	Pince palplanche	60TU
Max. Fréquence	2300	UPM	Poids	250 kg
Max. Amplitude sans 60TU	15	mm	Pince tube	
Max. Amplitude avec 60TU	13,8	mm	Poids	kg
Force de traction statique	120	kN		
Pression de travail max.	350	Bar	<b>Groupe hydraulique :</b>	
Débit d'huile max.	185	l/min	Modell	
Poids dynamique sans 60TU	985	kg		
Poids dynamique avec 60TU	1235	kg		
Poids total avec 60TU	1515	kg	<b>Huile lubrifiante :</b>	
Poids de transport	1615	kg	Quantité passée d' huile	22 l/min

Specificaties:		8RFB		
Excentrisch moment	0 – 7.5	kgm	<b>Klemmen :</b>	
Max. centrifugaalkracht	0 – 435	kN	Damwandklem	60TU
Max. toerental	2300	tpm	Gewicht	250 kg
Max. amplitude excl. 60TU	15	mm	Pijpenklem	
Max. amplitude incl. 60TU	13,8	mm	Gewicht	kg
Max. statische trekkracht	120	kN		
Max. werkdruk	350	bar	<b>Aggregaat :</b>	
Max. oliedoorstroming	185	l/min	Model	
Dyn. gewicht excl. 60TU	985	kg		
Dyn. gewicht incl. 60TU	1235	kg		
Totaalgewicht incl. 60TU	1515	kg	<b>Geforceerde smering :</b>	
Transportgewicht	1615	kg	Max. volumestroom olie	22 l/min

Especificaciones:		8RFB		
Momento excéntrico	0 – 7.5	kgm	<b>Mordaza :</b>	
Máx. centrífugo	0 – 435	kN	Abrazadera de hoja pila	60TU
Máx. acelerar	2300	rpm	Peso	250 kg
Máx. amplitud exclusivo 60 TU	15	mm	Pipe mordaza	
Máx. amplitud incluso 60TU	13,8	mm	Peso	kg
Máx. estático tracción	120	kN		
Máx. carga de trabajo	350	bar	<b>Unidad de potencia:</b>	
Máx. flujo aceite	185	l/min	Modelo	
Dyn. peso excl. 60 TU	985	kg		
Dyn. peso incl. 60 TU	1235	kg		
Peso total incl. 60 TU	1515	kg	<b>Forzado lubricación:</b>	
Peso con embalaje	1615	kg	Máx. flujo aceite	22 l/min